

City of Caldwell

Department of Building Safety



A GUIDE TO
**SINGLE FAMILY
DWELLING CONVERSIONS**

CHANGING FROM RESIDENTIAL USE TO NON-RESIDENTIAL USE

Getting Started

When converting a single family dwelling into a commercial use, requirements for new construction will apply. This is because the dwelling has never been a commercial use before. This basically means that whatever is feasible to do without jeopardizing, or tampering with the structural integrity of the building, will have to be done. Each department will have a set of requirements that will need to be addressed. Be advised that the main requirements will be items such as, Zoning, Landscaping, ADA Accessibility, Exiting, Signage, Parking, Door Hardware, and Door Widths. The Building Official may, at his discretion, require plans that are to be submitted, to be stamped by a registered architect or engineer. This would be when the use is to be other than a minor alteration to a “B” occupancy classification, such as general office.

Roundtable

Before you move too far forward with your project you will want to set up an appointment to sit in on one of the roundtable meetings. These are conducted every Thursday here in the Development Services building. Here is where you will get most of your questions answered regarding your project. A member of each department will be at the meetings to address questions regarding their department requirements. Roundtable meetings are not required, though strongly recommended. To schedule a meeting please contact the Planning & Zoning Department at 208-455-3021.

Submitting for a Permit

When you are ready to submit for a building permit you will need to submit two sets of plans or drawings and site plans with your permit application. Plans shall be detailed and address all requirements set forth in this handout. Plans shall also depict requirements as required by the Fire department, Engineering Department, and the Planning & Zoning Department. Permits for Plumbing, Electrical or Mechanical shall be secured prior to any work commenced for such trade. Turnaround times for these applications are around ten business days. **This handout depicts Building Department requirements only.**

ADA Requirements

Below is IBC section 3411.4.2 with the ADA requirements for a building that undergoes a complete change of occupancy. An example would be converting a single family dwelling into a commercial use, such as a commercial office. The occupancy group for the dwelling would be an “R-3” and the occupancy group for the office would be a “B”. This is an occupancy change. Note: The list does not include restrooms. As long as the restrooms are not included in any of the alterations, they would not need to be upgraded. Any alterations to the restrooms will require an upgrade to meet accessibility. When alterations affect primary function areas, 20% of the construction costs shall go towards improving the accessible route, i.e., lever hardware, removing barriers, door widths, entrance, parking.

3411.4.2 Complete change of occupancy.

Where an entire building undergoes a change of occupancy, it shall comply with Section 3411.4.1 and shall have all of the following *accessible* features:

1. At least one *accessible* building entrance.
2. At least one *accessible* route from an *accessible* building entrance to *primary function* areas.
3. Signage complying with [Section 1110](#).
4. *Accessible* parking, where parking is being provided.
5. At least one *accessible* passenger loading zone, when loading zones are provided.
6. At least one *accessible* route connecting *accessible* parking and *accessible* passenger loading zones to an *accessible* entrance. Twenty (20%) percent of the total construction cost shall go towards an accessible route. In this case, accessible route shall include restrooms.

Minimum Parking Requirements

Option #1

Option #2

Note:

- When only one ADA parking stall is required it shall be "Van Accessible" meeting one of the options shown.
- ADA parking stalls shall be located as close to the main entrance of the building as possible.
- Access aisles shall adjoin an accessible route.
- Access aisles shall not be less than 60" in width.
- Access aisles shall be marked to discourage parking in them.
- Two parking stalls shall be permitted to share a common access aisle.
- Van accessible parking shall be identified with signage designating "van accessible".

City of Caldwell
 208-455-3024
 Fax: 208-455-3050

Department of Building Safety

TITLE: **ADA PARKING STALL REQUIREMENTS FOR SINGLE STALL**

SIZE	CAGE CODE	DIWG NO	02-15	REV
SCALE	NTS	SHEET	1	

Planning and Zoning determines the amount of required parking stalls.

Total Spaces in Lot	Accessible Spaces Required
1-25	1 van
26-50	1 std. + 1 van
51 - 75	2 std. + 1 van
76-100	3 std. + 1 van
101-150	4 std. + 1 van
151-200	5 std. + 1 van
201-300	6 std. + 1 van
301-400	7 std. + 1 van
401-500	7 std. + 2 van
501-1000	2% of total spaces*
1001 and over	20 + (1 per 100 over 1000)*

Standard Accessible (std.) parking space is 8 foot minimum + 5 foot access aisle.

Accessible Route

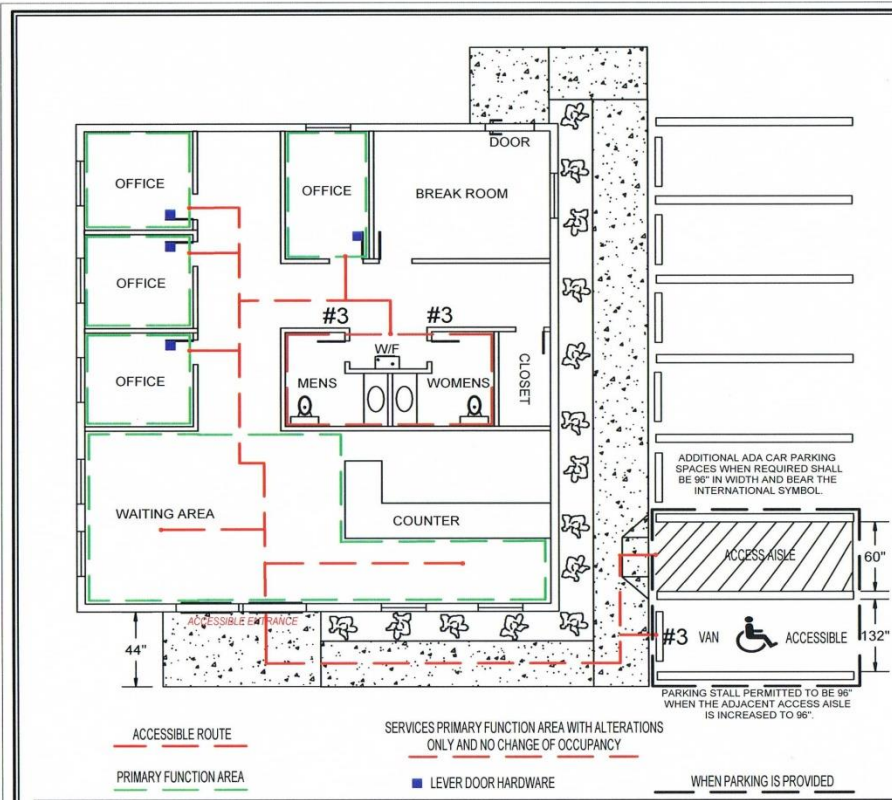

Change of Occupancy: Section 3411.4.2

1. At least one accessible building entrance.
2. At least one accessible route from an accessible building entrance to primary function areas.
3. ADA signage complying with section 1110.
4. Accessible parking, where parking is being provided.
5. At least one accessible passenger loading zone, when loading zones are provided.
6. At least one accessible route connecting accessible parking and accessible passenger loading zones to an accessible entrance.

Alterations Only: Section 3411.7

Where an alteration affects the accessibility to, or contains an area of primary function, the route to the primary function area shall be accessible.

1. Toilet facilities and water fountains shall be considered as servicing the primary function and is part of the accessible route.
2. The costs of providing the accessible route are not required to exceed 20 percent of the costs of the alteration affecting the area of primary function.

Exception:

Where the alteration is for the purpose of increasing accessibility.

General ADA Specifics for Existing Buildings:

Ramps: Slopes no steeper than 1:12. If space limitations apply, 1:12 to 1:10 with max. rise of 6 inches. Slopes 1:10 to 1:8 with max. rise of 3 inches. Width 36". Landings 5'. Handrails on both sides.

Door Widths: 32" net clear. This is for doors required to be altered as part of an accessible route.

Historic Buildings on the Register: Only one level required to be accessible. Limitations set so as to not threaten the historical significance of the building.

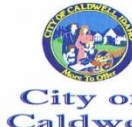
 <p>City of Caldwell 208-455-3024 Fax: 208-455-3050</p>		<p><i>Department of Building Safety</i></p>	
		<p>TITLE ADA REQUIREMENTS FOR CHANGE OF USE OR ALTERATIONS TO EXISTING BUILDINGS</p>	
SIZE	CAGE CODE	DWG NO	REV
		11-13	
SCALE	NTS	SHEET	1

Parts of the Accessible Route

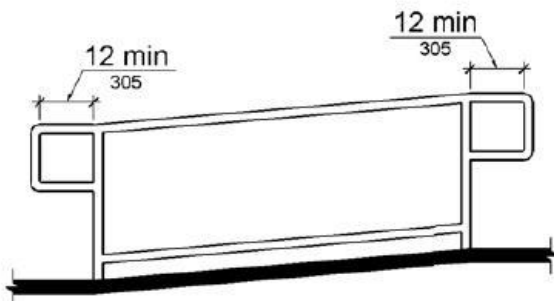

Figure 505.10.1
Top and Bottom Handrail Extension at Ramps

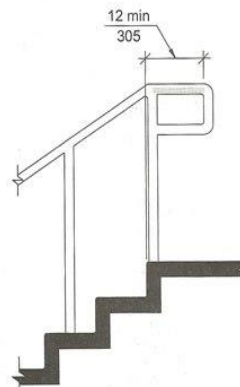

Fig. 505.10.2
Top Handrail Extensions at Stairs

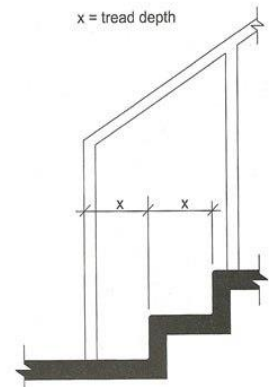
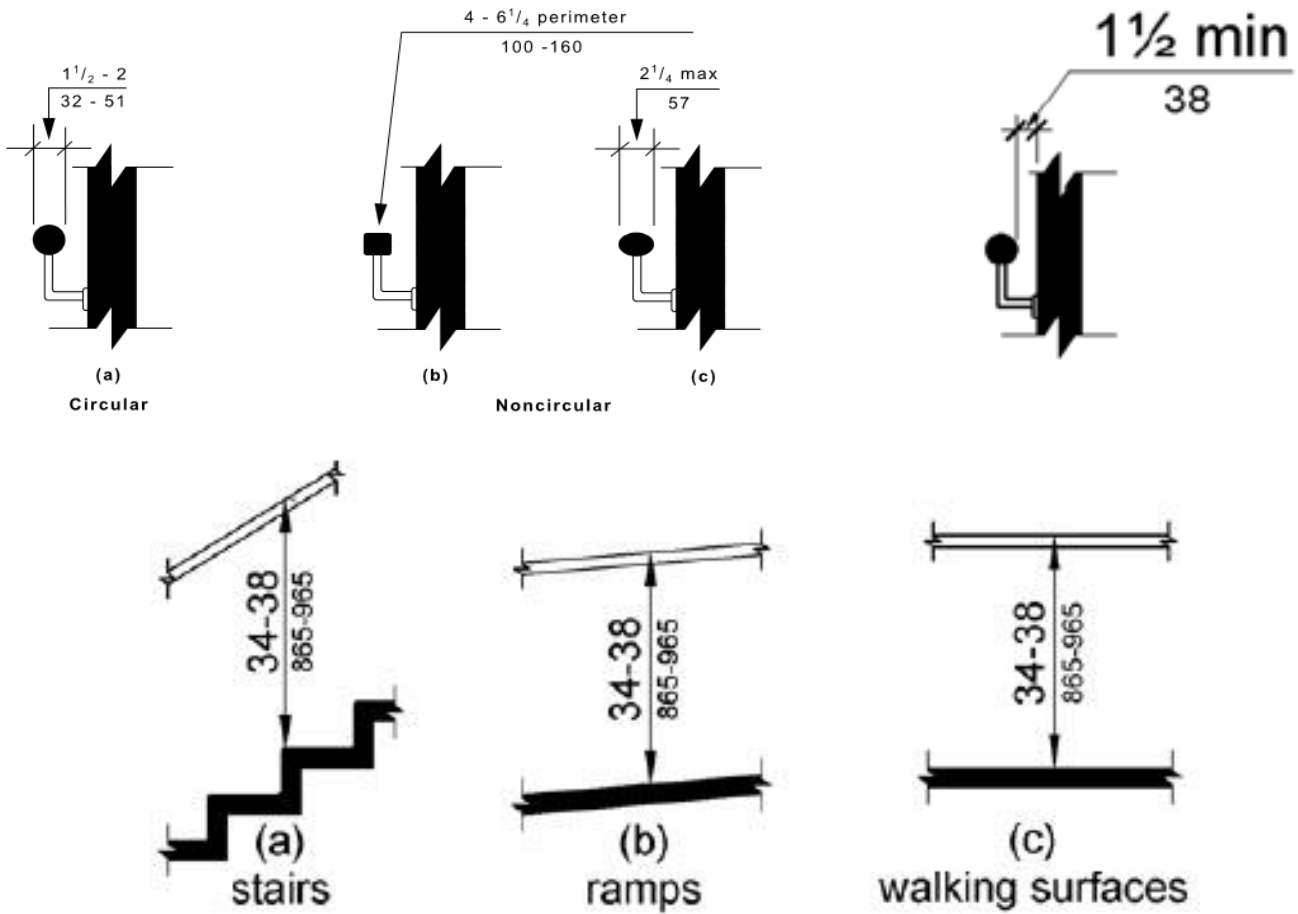
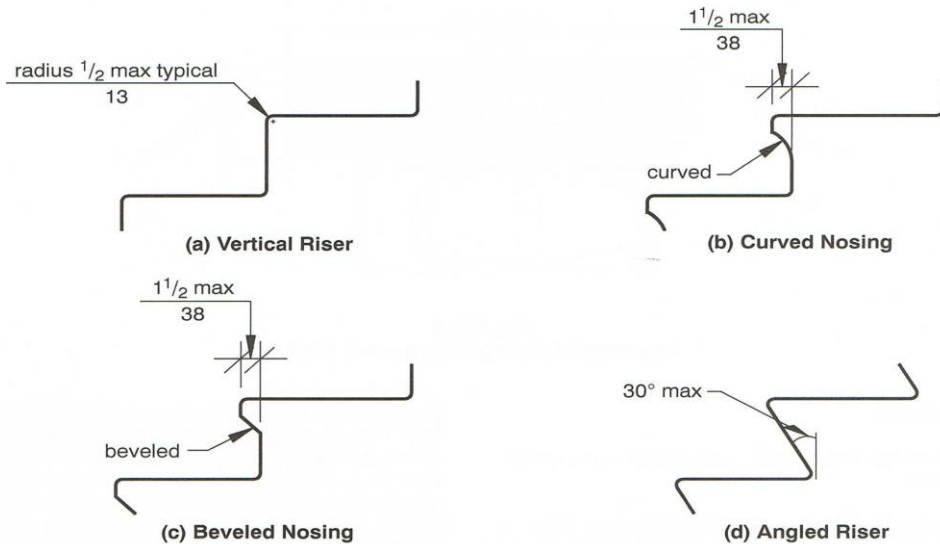

Fig. 505.10.3
Bottom Handrail Extensions at Stairs

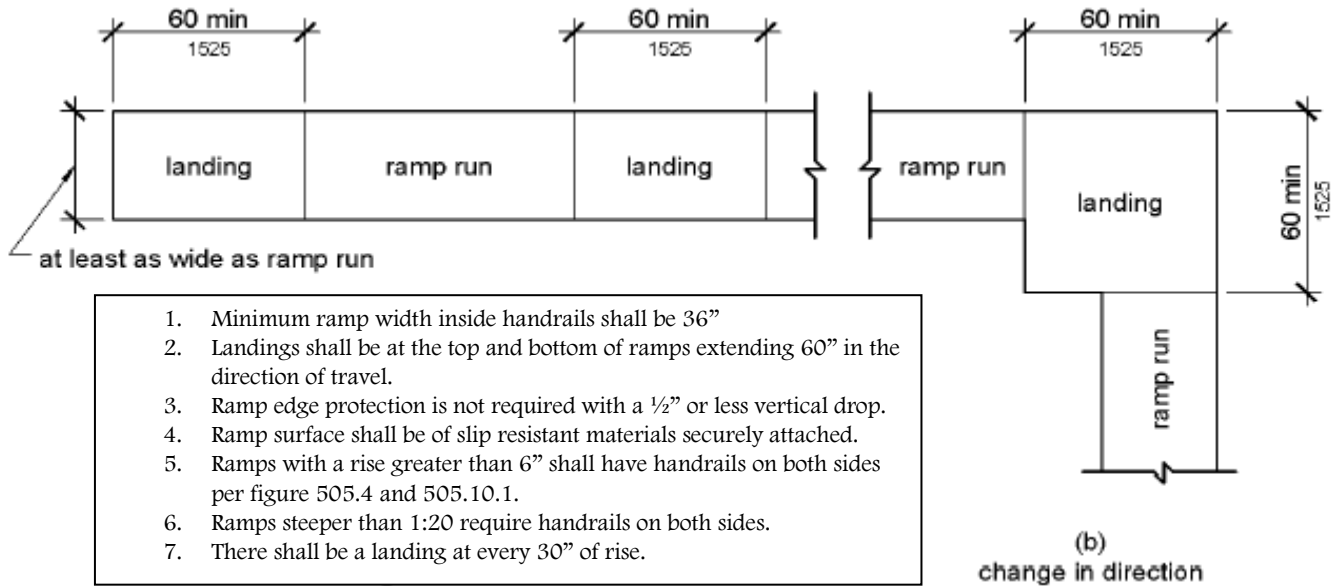

**Figure 505.4
Handrail Height**

Stairs - Minimum and Maximum Rise = 4" and 7" - Minimum Run = 11"



**Fig. 504.5
Stair Nosings**



Chapter 4. Accessible Routes

ICC/ANSI A117.1-2003

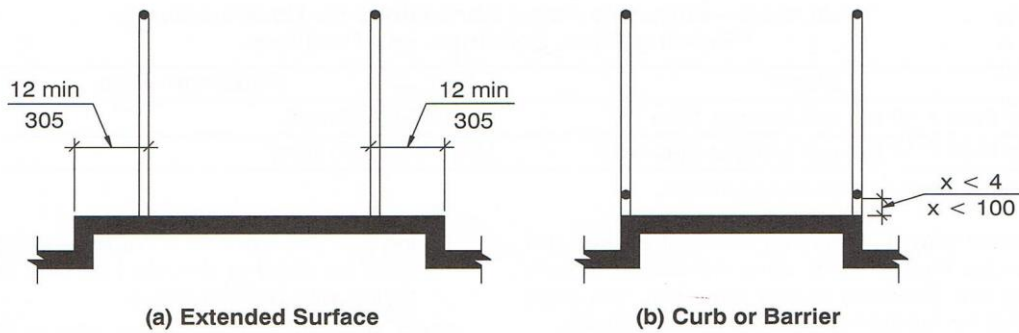

Fig. 405.9
Ramp Edge Protection

Doors

Table 404.2.3.1—Maneuvering Clearances at Manual Swinging Doors

TYPE OF USE		MINIMUM MANEUVERING CLEARANCES	
Approach Direction	Door Side	Perpendicular to Doorway	Parallel to Doorway (beyond latch unless noted)
From front	Pull	60 inches (1525 mm)	18 inches (455 mm)
From front	Push	48 inches (1220 mm)	0 inches (0 mm) ³
From hinge side	Pull	60 inches (1525 mm)	36 inches (915 mm)
From hinge side	Pull	54 inches (1370 mm)	42 inches (1065 mm)
From hinge side	Push	42 inches (1065 mm) ¹	22 inches (560 mm) ^{3 & 4}
From latch side	Pull	48 inches (1220 mm) ²	24 inches (610 mm)
From latch side	Push	42 inches (1065 mm) ²	24 inches (610 mm)

¹Add 6 inches (150 mm) if closer and latch provided.

²Add 6 inches (150 mm) if closer provided.

³Add 12 inches (305 mm) beyond latch if closer and latch provided.

⁴Beyond hinge side.

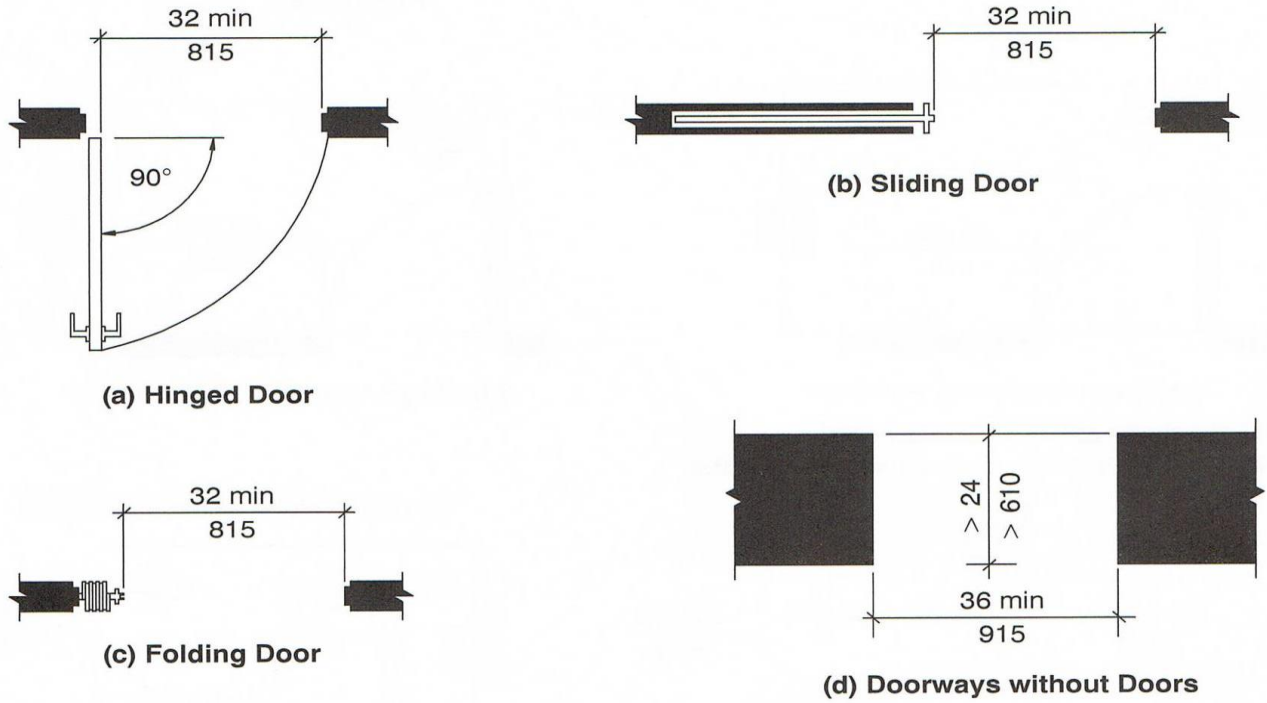
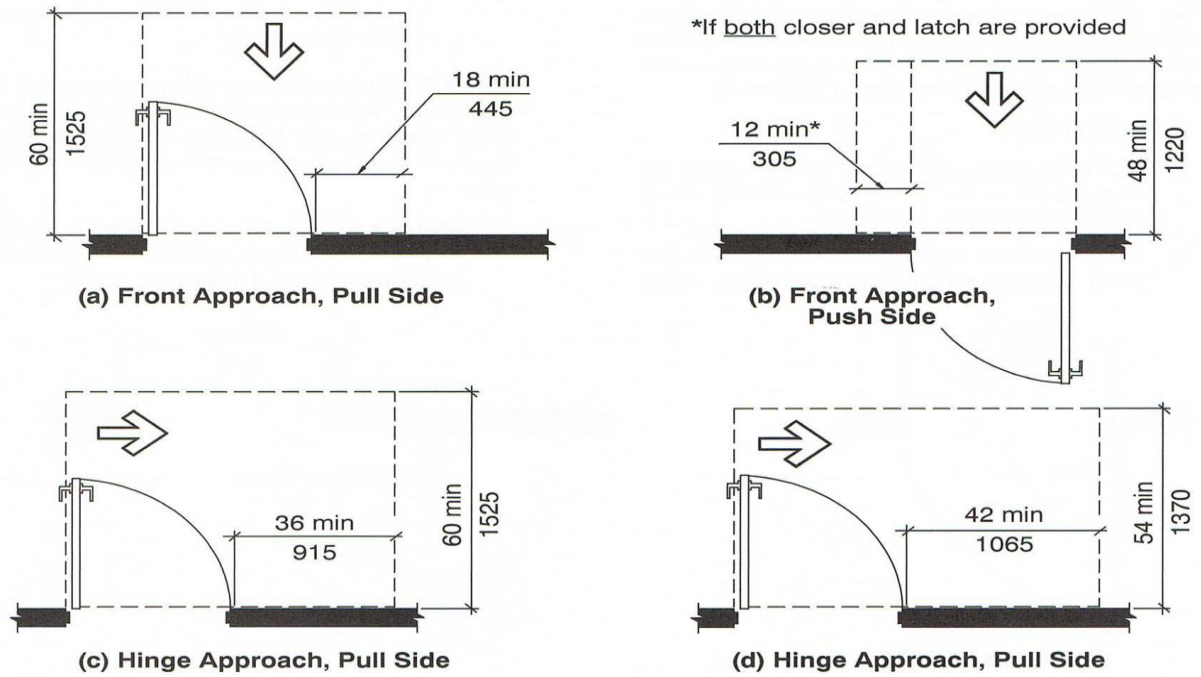

Fig. 404.2.2
Clear Width of Doorways

Door Approach

Chapter 4. Accessible Routes

ICC/ANSI A117.1-2003



*If both closer and latch are provided

* If both closer and latch are provided
 ** 48 min (1220) if both closed and latch provided

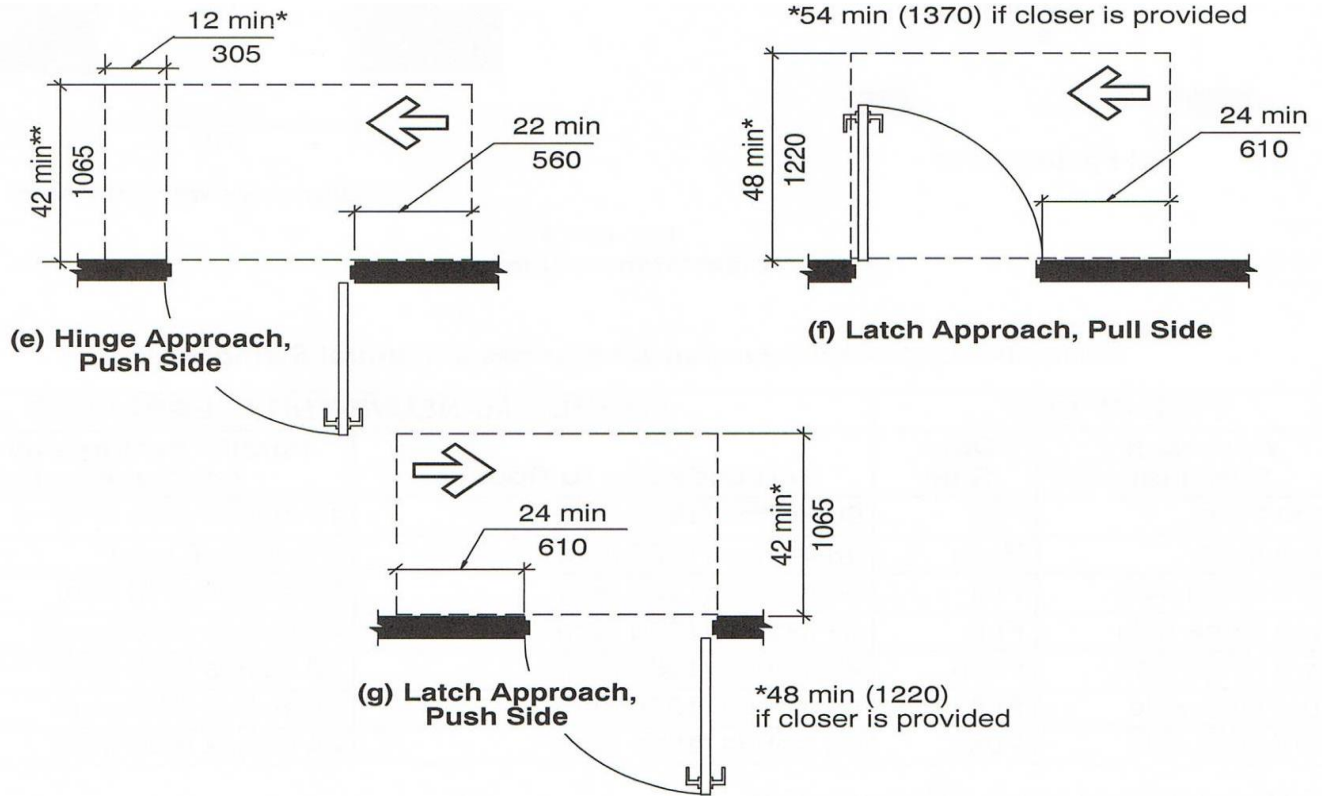
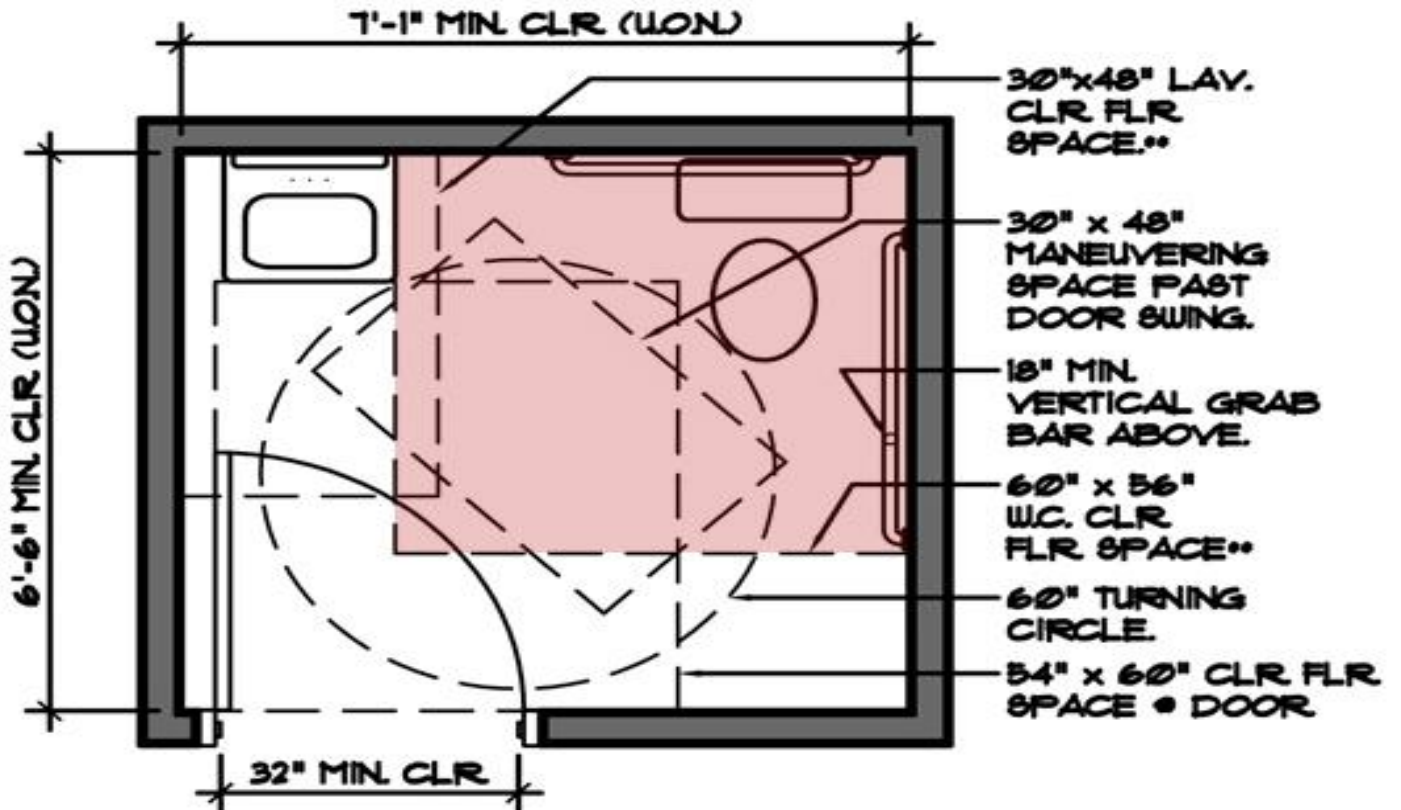
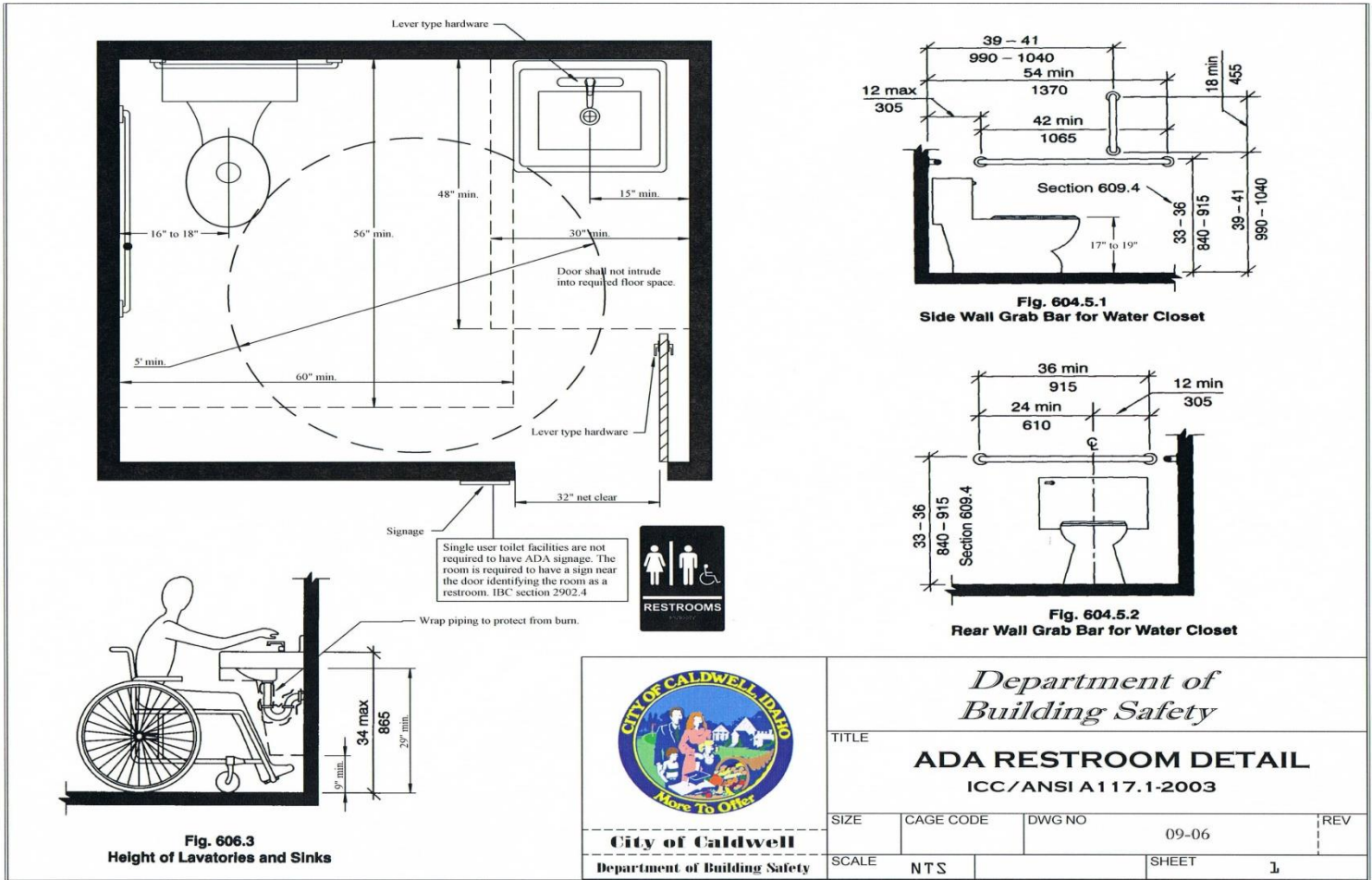

Fig. 404.2.3.1
Maneuvering Clearance at Manual Swinging Doors

Restrooms (when altered) – Single User





Typically, single family dwelling conversions are minor enough to only require a single user/unisex facility. If the occupant load exceeds 15, then separate his/her facilities will be required. In a change of occupancy, restrooms are only required to meet accessibility when they are in the scope of work for alterations. This means if you are planning on remodeling the restroom, then it would have to be brought up to ADA standards. Note: Restrooms are considered public and employee restrooms, so you want to take this in to account in your design plans.

General Code Requirements:

1008.1.7 Thresholds.

Thresholds at doorways shall not exceed 3/4 inch (19.1 mm) in height above the finished floor or landing for sliding doors serving *dwelling units* or 1/2 inch (12.7 mm) above the finished floor or landing for other doors. Raised thresholds and floor level changes greater than 1/4 inch (6.4 mm) at doorways shall be beveled with a slope not greater than one unit vertical in two units horizontal (50-percent slope).

1008.1.9.1 Hardware.

Door handles, pulls, latches, locks and other operating devices on doors required to be *accessible* by [Chapter 11](#) shall not require tight grasping, tight pinching or twisting of the wrist to operate.

1008.1.9.3 Locks and latches.

Locks and latches shall be permitted to prevent operation of doors where any of the following exists:

1. Places of detention or restraint.
2. In buildings in occupancy Group A having an *occupant load* of 300 or less, Groups B, F, M and S, and in *places of religious worship*, the main exterior door or doors are permitted to be equipped with key-operated locking devices from the egress side provided:
 - 2.1. The locking device is readily distinguishable as locked;
 - 2.2. A readily visible durable sign is posted on the egress side on or adjacent to the door stating: THIS DOOR TO REMAIN UNLOCKED WHEN BUILDING IS OCCUPIED. The sign shall be in letters 1 inch (25 mm) high on a contrasting background; and
 - 2.3. The use of the key-operated locking device is revokable by the *building official* for due cause.
3. Where egress doors are used in pairs, *approved* automatic flush bolts shall be permitted to be used, provided that the door leaf having the automatic flush bolts has no doorknob or surface-mounted hardware.

General Code Requirements cont:**1105.1 Public entrances.**

In addition to *accessible* entrances required by [Sections 1105.1.1](#) through [1105.1.6](#), at least 60 percent of all *public entrances* shall be *accessible*.

Exceptions:

1. An *accessible* entrance is not required to areas not required to be *accessible*.
2. Loading and *service entrances* that are not the only entrance to a tenant space.

TABLE 1607.1 MINIMUM UNIFORMLY DISTRIBUTED LIVE LOADS, L_o , AND MINIMUM CONCENTRATED LIVE LOADS

EXAMPLE USING ONLY TWO SEPARATE COMMERCIAL OCCUPANCIES

OCCUPANCY OR USE	UNIFORM (psf)	CONCENTRATED (lbs.)
------------------	------------------	------------------------

Residential

25. Residential		
One- and two-family dwellings:		
Uninhabitable attics without storage ⁱ	10	
Uninhabitable attics with storage ^{i, j, k}	20	—
Habitable attics and sleeping areas ^k	30	
All other areas	40	

Commercial

9. Dining rooms and restaurants	100 ^m	—
---------------------------------	------------------	---

22. Office buildings:		
Corridors above first floor	80	2,000
File and computer rooms shall be designed for heavier loads based on anticipated occupancy	—	—
Lobbies and first-floor corridors	100	2,000
Offices	50	2,000

The load tables above demonstrate the differences in required floor load design for different uses and occupancies. So on a general note, if you have an existing single family dwelling with a maximum floor load design of 40 psf., and your proposed change of use is going to be a small restaurant or dining area that has a minimum required floor design load of 100 psf., or an office that has a lobby with a minimum floor load of 100 psf., the Building Official may require a structural evaluation of the floor system prior to permit approval.

3404.3.1 Design live load.

Where the *alteration* does not result in increased design live load, existing gravity load-carrying structural elements shall be permitted to be evaluated and designed for live loads *approved* prior to the *alteration*. If the *approved* live load is less than that required by [Section 1607](#), the area designed for the nonconforming live load shall be posted with placards of *approved* design indicating the *approved* live load. Where the *alteration* does result in increased design live load, the live load required by [Section 1607](#) shall be used.

General Code Requirements cont:

3411.2 Maintenance of facilities.

A facility that is constructed or altered to be *accessible* shall be maintained *accessible* during occupancy.

Nail Salons

TABLE 403.3—continued MINIMUM VENTILATION RATES

OCCUPANCY CLASSIFICATION	OCCUPANT DENSITY #/1000 FT ^{2a}	PEOPLE OUTDOOR AIRFLOW RATE IN BREATHING ZONE, R _p CFM/PERSON	AREA OUTDOOR AIRFLOW RATE IN BREATHING ZONE, R _a CFM/FT ^{2a}	EXHAUST AIRFLOW RATE CFM/FT ^{2a}
Specialty shops				
Automotive motor-fuel dispensing stations ^b	—	—	—	1.5
Barber	25	7.5	0.06	0.5
Beauty salons ^b	25	20	0.12	0.6
Nail salons b, h	25	20	0.12	0.6

b. Mechanical exhaust required and the recirculation of air from such spaces is prohibited (see [Section 403.2.1](#), Item 3).

h. For nail salons, each nail station shall be provided with a *source capture system* capable of exhausting not less than 50 cfm per station.

403.2.1 Recirculation of air.

The outdoor air required by [Section 403.3](#) shall not be recirculated. Air in excess of that required by [Section 403.3](#) shall not be prohibited from being recirculated as a component of supply air to building spaces, except that:

- 3. Where mechanical exhaust is required by Note **b** in Table 403.3, recirculation of air from such spaces shall be prohibited. All air supplied to such spaces shall be exhausted, including any air in excess of that required by Table 403.3.

For the protection of the occupants, an independent exhaust system shall be designed for nail salons so that fumes and dust are exhausted from points of service to the exterior of the building.

Nail salons source capture mechanical exhaust systems shall be in operation while work is in progress, by interlocking the system to station lighting or other equivalent means. Make up air shall be required and designed for the entire ventilation system eliminating any re-circulation of toxic air back into the building. These ventilation systems shall be designed by a registered engineer.